

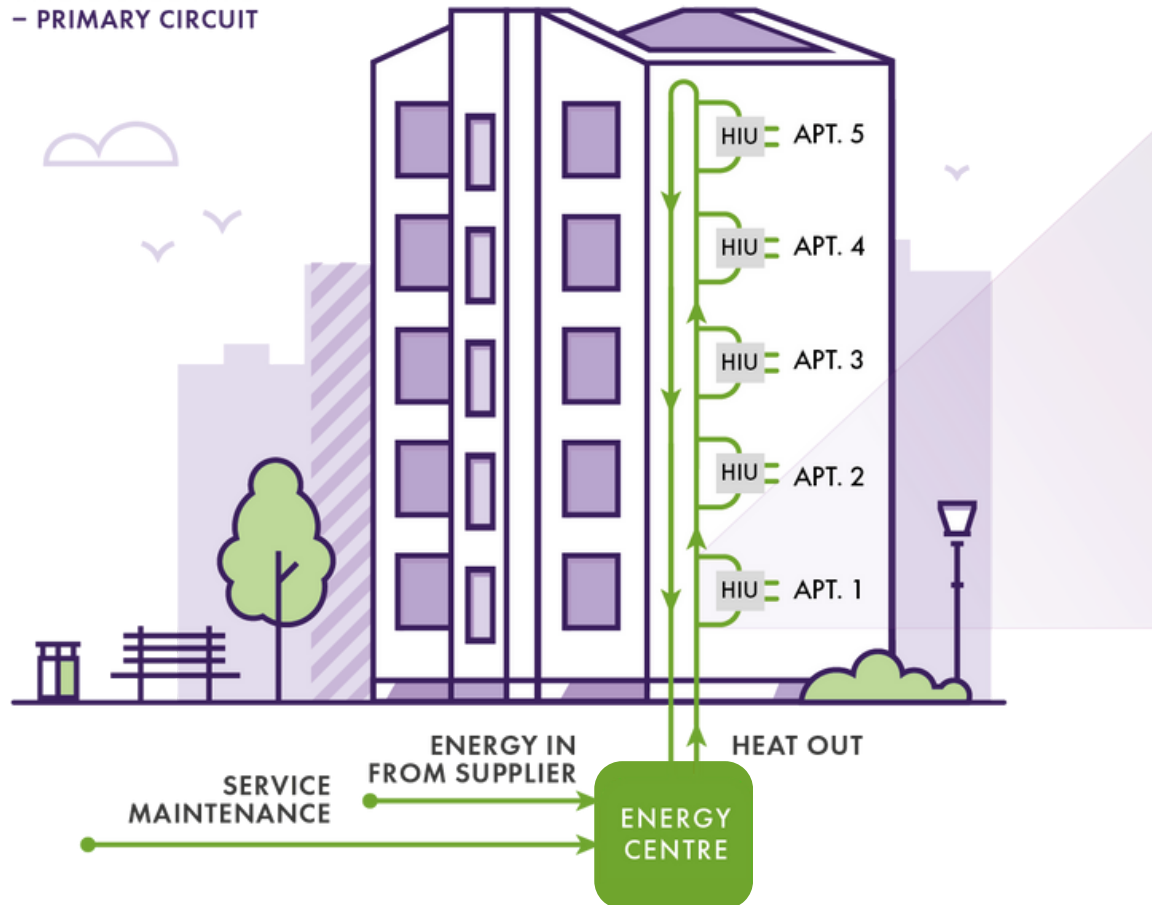

iKnoWatt

Your Prepayment Unit  
IKW2 Secure User Manual

## THE BUILDING - PRIMARY CIRCUIT



## What is a heat network?

Heat networks are a low-carbon solution for supplying heat and hot water to large apartment blocks and play a key role in the UK's transition to net zero. These systems offer a wealth of financial, social and environmental benefits, allowing you access to heat and hot water instantly, whenever you need it.

## How does it work?

Heat is generated in a central location (i.e. basement energy centre) and distributed to each apartment through a network of pipes known as the primary circuit. Instead of individual gas boilers, each apartment is fitted with a Heat Interface Unit (HIU), which transfers heat from the primary circuit to the secondary circuit within your home.

The secondary circuit is a network of pipes supplying space heating and hot water. Your HIU is fitted with a heat meter which accurately records the amount of energy each apartment extracts from the primary circuit.

## APARTMENT 1

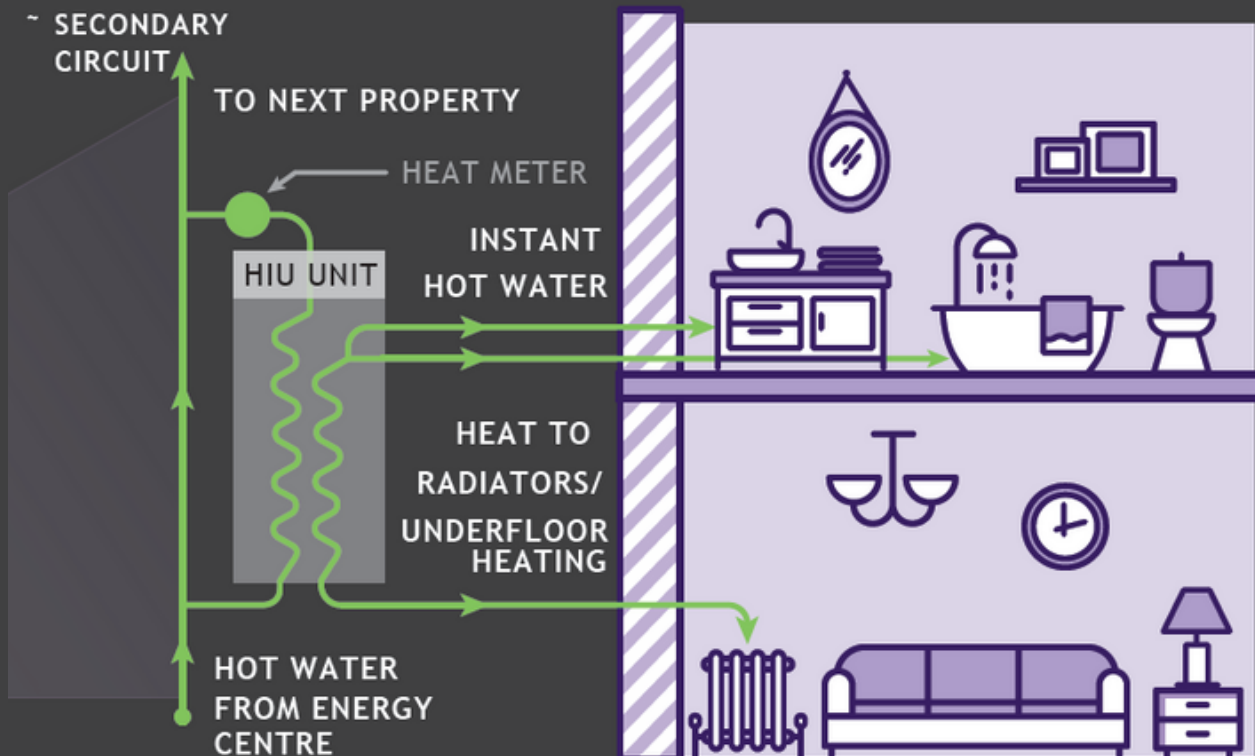

Your apartment has the added facility of iKnoWatt; allowing you complete control and the ability to only pay for what you use. You won't receive paper invoices and you're only required to top up as and when you need to.

## The iKnoWatt Solution

Partnered with your In-Home Display, iKnoWatt allows you to:

- View real-time usage and 12 months of consumption history
- Set alerts for when you've consumed over a certain amount, or if you're low on credit
- View account notifications from your Heat Supplier





## Your In-Home Display

Your In-Home Display is touch-screen and easy to navigate.

The LCD interface displays a set of recognisable icons, representing each function.

Please note, your device might display additional utilities depending on the arrangements made with your Heat Supplier.

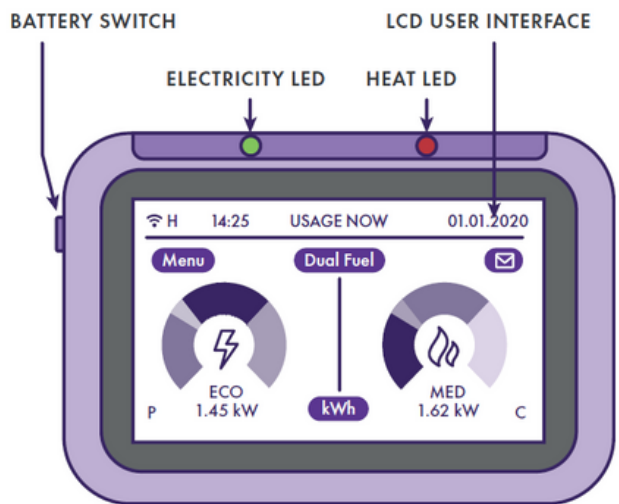

Gives access to **heat only** Home Screen



Gives access to **dual-fuel** Home Screen



Gives access to **electricity only** Home Screen



Gives access to **messages** screen



Gives access to the **History** screen



Gives access to the **Tariff** screen



Gives access to the **Account** screen



Gives access to the **Settings** screen

# Frequently Asked Questions

## How can I pay?

### PayPoint In Store:

You will be provided with a prepayment card which can be used across numerous retail outlets facilitating PayPoint. No registration is required, and your card will be ready to use straight away.

### Paypoint Online:

On the back of your prepayment card, there is a unique PayPoint number. This can be used to register for PayPoint Online, where you can top up, view your balance and track your payment history.

Register for PayPoint Online:  
[iknowattpayments.paypoint.com/energy](http://iknowattpayments.paypoint.com/energy)

### Card:

Our dedicated Customer Care team are available to process card payments.

## What if I move home?

It's important you notify us when moving home so we can close your account and refund any existing credit to your bank account.

Please contact our Customer Care team to notify us of your move and request a refund.

## What if I can't top up?

If you unexpectedly find yourself running out of credit, there's no need to panic.

When you reach £0, your emergency credit will automatically activate.

If you exceed your emergency credit limit, your supply will be isolated and you will no longer receive access to heat or hot water. In this instance, you will need to make a top up to resume supply.

## What if my meter is faulty?

If there's no heat or hot water supply to your flat, please firstly check that your account is in credit.

If your balance is negative or reflects £0, you will need to top up to resume supply.

If your account is in credit and you suspect your Heat Interface Unit (HIU) is faulty, please contact your landlord.

We are unable to help with HIU issues and your landlord will need to arrange a resolution with the company responsible for maintaining these units.

Call our team on **01279 810 119**  
Monday - Thursday, 9am - 4pm



We're here to help. If you experience any issues or require support, please find some helpful advice at our Residents Hub. Here, you can access our dedicated Customer Care team through the Help Centre, who are on hand to take billing queries and explain tariffs. Please contact us via:

**W** [dataenergy.co.uk/residents](https://dataenergy.co.uk/residents)

**T** 01279 810 119

[dataenergy.co.uk](https://dataenergy.co.uk)